

resistance welding

DC Tech Series

Inverter Power Supplies

IS-120B Spot Welder
IS-443B Seam Welder
IS-444B Spot Welder
IS-470B Seam Welder
IS-471B Spot Welder
ISA-500A Spot Welder



Features

- **High Speed Adaptive Feedback**

Produces consistent, reliable welds with optimal nugget formation, superior joint strength and excellent surface appearance

- **Process Control**

Provides millisecond control over the resistance welding process

- **Closed-Loop Feedback**

A feedback rate of every 500 microseconds, maintains programmed weld current or power

- **Technically Advanced Inverter Technology**

Improves spot and seam welding of traditionally “hard to weld” materials including coated steels, aluminum, brass and copper

- **Shorter Weld Times**

Compared to conventional AC welders, DC Inverter technology produces heat more efficiently, thus decreasing weld times as much as three to one and reducing the heat affected zone (HAZ)

Spirit Of Innovation™
MIYACHI
UNITEK™

Miyachi Unitek, a pioneer in inverter resistance welding, now offers its complete family of DC-Tech inverter power supplies for resistance welding applications. With rated capacities up to 325kVA, DC-Tech delivers superior weld quality by utilizing lower weld currents, shorter weld times and lower weld forces than conventional AC controls. Utilizing high speed, real time, adaptive feedback control to carefully regulate weld current and heat generation, and reduce energy usage while increasing electrode life. Multiple weld monitor functions enable the user to control the resistance welding process, improve weld quality, increase production efficiency and reduce cost.

Closed Loop Feedback Control

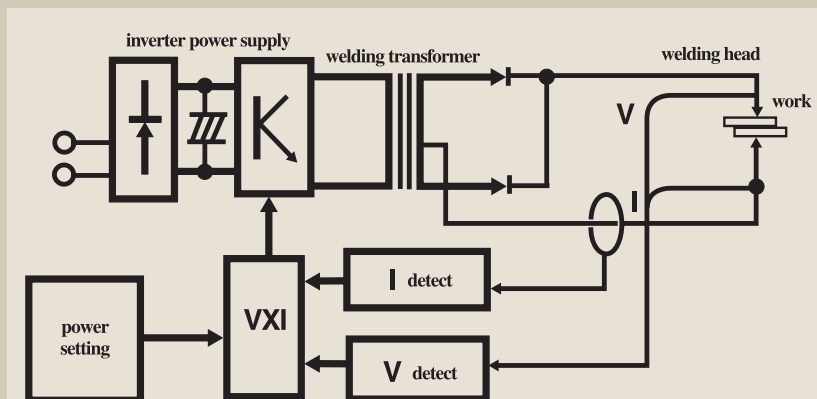

Closed-loop feedback circuit maintains programmed weld current or power (selectable by user) by measuring and adjusting secondary current and voltage. With a feedback rate of every 500 micro-seconds, consistent weld current (or power) at the electrodes is maintained, overcoming power fluctuations and material workpiece variances that hurt weld quality.



Seam Weld Power Supplies

Typical Applications and Uses:

- Water filtration components
- Vehicle fuel tanks
- Aluminum and titanium aircraft components
- Heavy gauge wire shelving
- High speed bi-metal electrical contacts



Spot Weld Power Supplies

Typical Applications and Uses:

- Stainless and galvanized doors and furniture
- Automotive sheet metal and components
- Aluminum structural components
- Copper wire solidification
- High speed copper to galvanized cross wire welds
- Motor armature fusing



Programming Made Easy



- **MA-627A Remote Program Unit** – Used to store weld schedules and program multiple units.
- **MA-628A Monitor Unit** – Adds process security by displaying Current, Power, Time and Error data while inhibiting access to programming.

DC-Tech Ordering Guide

System Requirements*:

- Inverter Power Supply
(See back page)
- Program Unit (MA-627A)
- Toroidal Coil
- Inverter Transformer
(See table below)
- Optional Monitor Box (MA-628A)

Model	IT-40	IT-85	IT-130	IT-250
IS-120B (spot)	•	•		
IS-444B (spot)		•	•	
ISA-500A (spot)			•	
IS-471B (spot)			•	•
IS-443B (seam)		•	•	
IS-470B (seam)			•	•

*Each item sold separately.

See back page for complete specifications.

Inverter Welding Delivers Performance & Payback

With quality and production demands increasing, DC inverter resistance welding offers benefits that traditional AC welding cannot address; in the broadest sense, inverter welding offers more flexibility than conventional AC resistance welding. Virtually any application that can be done with an AC weld control can also be done with inverter technology.

Inverter Performance Benefits

Many resistance weld failures can be traced to inconsistent secondary welding current. Adaptive feedback systems used in inverter technology utilize pulse width modulation to continuously monitor and adjust the weld current throughout the weld, compensating for non-uniform workpiece resistance, worn electrodes, and power source fluctuations, resulting in extremely consistent weld current delivery throughout every weld. The benefits derived include shorter weld times, lower currents and forces, faster speed and throughput, longer electrode life, less weld splash and less part (surface) deformation.

Efficient Weld Current Delivery Improves Quality

In resistance welding, a weld joint (or nugget) is formed as weld current flows through the workpieces, encounters different electrical resistances and generates heat. AC controls, by definition, cycle weld current on and off twice per cycle. This AC “cycling” can cause embrittlement and irregular nugget formation, hurting weld quality and strength. By contrast, inverter systems deliver current without cycling, thus continuously heat the weldments. Weld times can be adjusted in one millisecond increments. This precise control allows inverter welders to utilize shorter weld times and control how current is introduced to the parts; that is to say, to shape the current waveform. As a result, lower weld current and less force (compared to an AC weld control) can be utilized to achieve the desired molten state of the weldments for optimal nugget formation.

Hard to Weld Materials

Inverters are capable of successfully welding a broad range of materials. Softer metals, particularly those with high electrical and thermal conductivity are good candidates for inverter resistance welding. High electrical conductivity means that higher welding currents must be used. High thermal conductivity requires that the weld current must be delivered quickly to minimize the heat affected zone. Zinc-coated galvanized steels also fall into this category.

Transformer Size & High Current Output

Compact inverter equipment features small, lightweight welding transformers for use in manual, automated and robotic (transgun) configurations. In AC resistance welding, higher current outputs typically require extremely large transformers. The physical size and weight of the AC welding transformer is especially critical in transgun configurations, often limiting the current output available. Inverter transformers are often as much as 50% smaller, lighter, and deliver higher current outputs than conventional AC transguns.

Inverter Realities

Inverter performance benefits can result in higher production rates with less time lost to electrode maintenance and changes. According to many manufacturers, weld failures, part rejects, and costly re-work have been dramatically reduced. Shorter weld times, lower weld currents and balanced line loads lessen the primary current demand also reducing electrical usage and expense. Adaptive feedback control modes and millisecond programming make precise control over the resistance welding process a reality. DC inverter welding allows for a broader process window to overcome workpiece variances and production challenges. This larger process window is one of the primary reasons that inverter welding meets today’s demand for higher quality and delivers such attractive returns on investment.

Specifications

Power Supply Model	IS-120B	IS-444B	Spot Weld ISA-500A	IS-471B	Seam/Roll Spot IS-443B	IS-470B
Power Source	3 phase 480VAC / 440VAC / 400VAC / 220VAC +10% -15% 50/60 Hz.					
Output Frequency	1 kHz / 800 Hz / 600Hz (selectable)					
Output Voltage	Single phase 650V, peak @ 480V input					
Rated Capacity	52kVA @ 480 VAC	182kVA @ 480 VAC	325kVA @ 480 VAC	182kVA @ 480 VAC	325kVA @ 480 VAC	
Max. Primary Output Current	200A (8% duty cycle)	500A (15% duty cycle)	1000A (12% duty cycle)	500A (15% duty cycle)	1000A (12% duty cycle)	
Control Systems	Secondary Constant Current Secondary Constant Power Primary Constant Current (RMS) Primary Constant Current (Peak) Fixed Pulse Secondary Constant Voltage	Secondary Constant Current Secondary Constant Power Primary Constant Current (RMS) Primary Constant Current (Peak) Fixed Pulse		Primary Constant Current (PWM RMS Value) Primary Constant Current (PWM Effective Peak) Fixed Pulse		
Control Modes	n/a		Forging, Chaining, Successive	n/a		
Weld Schedules	15 schedules		15 schedules		7 schedules	
Timer Settings	<i>ms Mode</i>	<i>Cycle Mode</i>	<i>ms Mode</i>	<i>Cycle Mode</i>	<i>ms Mode</i>	
Squeeze Delay	0000-9999ms	000-999cyc	0000-9999ms	000-999cyc	n/a	
Squeeze Delay	0000-9999ms	000-999cyc	0000-9999ms	000-999cyc	0000-9999ms	
Delay	n/a	n/a	n/a	n/a	000-999ms	
Weld 1	000-600ms	00-30cyc	000-600ms	00-30cyc	000-600ms	
Upslope	000-400ms	00-20cyc	000-400ms	00-20cyc	000-400ms (included in Weld 1)	
Cool	000-999ms	00-99cyc	000-999ms	00-99cyc	000-999ms	
Weld 2	000-600ms	00-30cyc	000-600ms	00-30cyc	n/a	
Downslope	000-400ms	00-20cyc	000-400ms	00-20cyc	n/a	
Hold	000-999ms	00-99cyc	000-999ms	00-99cyc	000-999ms	
Off	0000-9990ms	00-99cyc	0000-9990ms	00-99cyc	n/a	
Pulses	1-9	1-9	1-9	1-9	1-9	
Max. Secondary Current Settings	0.1 - 20.0kA		2.0 - 40.0kA	4.0 - 80.0kA	1.0 - 20.0kA	2.0 - 40.0kA
Weld Monitors	00.0-20.0kA		00.0-40.0kA	00.0-80.0kA	00.0-20.0kA	00.0-40.0kA
Current	00.0-9.99V		0.00-9.99V	0.00-9.99V	n/a	n/a
Voltage	00.0-20.0kW		00.0-40.0kW	00.0-80.0kW	n/a	n/a
Power	10%-100%		10%-100%	10%-100%	10%-100%	10%-100%
Pulse Width						
Program Unit	MA-627A (sold separately)					
Monitor Unit	MA-628A (sold separately)				n/a	
Physical Characteristics						
Dimensions Inches	11.0 x 7.00 x 25.0	27.0 x 12.0 x 20.0	27.0 x 12.0 x 26.0	27.0 x 12.0 x 20.0	27.0 x 12.0 x 26.0	
H x W x D (mm)	(279 x 178 x 635)	(686 x 305 x 508)	(686 x 305 x 660)	(686 x 305 x 508)	(686 x 305 x 660)	
Weight: lbs (kg)	33 (15)	99 (45)	139 (63)	99 (45)	139 (63)	

Transformer Model	IT-40	IT-85	IT-130	IT-250
Rated Capacity	40kVA @ 50%	85kVA @ 50%	130kVA @ 50%	250kVA @ 50%
Max. Input Voltage	650V	650V	650V	650V
Input Frequency	1000 Hz	1000 Hz	1000 Hz	1000 Hz
Unloaded Secondary Voltage/Turns Ratio	4.28V (152:1), 8.55V (76:1)	8.9V (73:1), 9.5V (68:1)	13.0V (50:1), 13.8V (41:1)	13.0V (50:1)
Cooling Water	1 gal/per min.	2 gal/per min.	4 gal/per min.	4 gal/per min.
Dimensions Inches (H x W x D) (mm)	6.75 x 5.00 x 14.9 (171 x 127 x 378)	6.75 x 6.00 x 11.9 (171 x 152 x 302)	10.3 x 6.00 x 15.5 (262 x 152 x 394)	10.3 x 7.75 x 19.0 (262 x 197 x 483)
Weight lbs. (Kg)	60 (27)	60 (27)	110 (50)	130 (59)

Your Local Representative



Corporate Office: 1820 S. Myrtle Ave. • P.O. Box 5033 • Monrovia, CA 91017-7133 USA
 Tel: (626) 303-5676 • FAX: (626) 358-8048 • E-Mail: info@miyachiunitek.com
 Internet <http://www.miyachiunitek.com> • ISO 9001 Certified Company

EASTERN (USA) Sales Office:
 170 Cross Street
 Boylston, MA 01505
 Tel: (508) 869-0583
 FAX: (508) 869-0585
 E-Mail: eastsales@miyachiunitek.com

ASIA Sales Office:
 Unit D, 20/F, Infotech Centre
 21 Hung To Road
 Kwun Tong, Hong Kong
 Tel: +852 2833-6998
 FAX: +852 2833-6672
 E-Mail: asiapacific@miyachiunitek.com

UNITEK EAPRO:
 Schootense Dreef 21
 NL-5708 HZ Helmond
 The Netherlands
 Tel: +31 492-54-22-25
 FAX: +31 492-53-62-22
 E-Mail: info@unitekapro.com

Specifications subject to change without notice.
 Copyright© 2006 Miyachi Unitek Corporation. The material contained herein cannot be reproduced or used in any other way without the express written permission of Miyachi Unitek Corporation. All rights reserved.